



81st AYC Annual Regatta 2017

Organizing Authority: Annapolis Yacht Club
Annapolis, Maryland, USA

Event Website: <http://www.annapolisyc.com/racing/regattas>

This PDF bundle includes Amendment #1 to the Sailing Instructions.

There are two separate racing areas that make up the AYC Annual Regatta. Each racing area has a separate Sailing Instructions **that is included in the following pages** of this document.

For the **J/105, J/80, J/30, and J/22** classes, please see the Sailing Instructions for the **Drop Marks Course**.

For all **PHRF and Cruising** classes, please see the Sailing Instructions for **Fixed Marks Course**.



81st AYC Annual Regatta

June 10, 2017

Organizing Authority: Annapolis Yacht Club
Annapolis, Maryland, USA

Event Website: <http://www.annapolisyc.com/racing/regattas>

SAILING INSTRUCTIONS - DROP MARKS COURSE

The notation '[DP]' in a rule in the sailing instructions (SIs) or notice of race (NoR) means that the penalty for a breach of that rule may, at the discretion of the protest committee, be less than disqualification. The notation '[NP]' in a rule of the SIs or NoR means that a boat may not protest another boat for breaking that rule. This changes RRS 60.1(a).

1 RULES

1.1 The regatta will be governed by the rules as defined in The Racing Rules of Sailing (RRS).

2 COMMUNICATIONS WITH COMPETITORS

2.1 Notices to competitors will be posted on the official notice board at:
https://yachtscoring.com/notice_board_summary.cfm?eID=3030

2.2 On the water, the race committee intends to monitor and communicate with competitors via VHF radio on channel 72.

3 CHANGES TO SAILING INSTRUCTIONS

3.1 Any change to the SIs will be posted no later than 2 hours before the first scheduled warning signal on the day it will take effect, except that any change to the schedule of races will be posted by 2000 on the day before it will take effect.

4 SIGNALS MADE ASHORE

4.1 Signals flown ashore will be flown from the flagpole at the AYC Junior Sailing Center.

4.2 When flag AP is displayed ashore '1 minute' is replaced with 'not less than 60 minutes' in the race signal AP.

5 SCHEDULE OF RACES

5.1 The scheduled time of the warning signal for the first race of the day is 1130.

5.2 A total of 3 races are scheduled.

5.3 No warning signal will be made after 1600.

5.4 All competitors are invited to a post-race party and awards presentation at the AYC Sailing Center at 1800 with complimentary beer and hors d'oeuvres.

6 CLASS FLAGS

6.1 The class flags are:

Class	Class flag
J/22	Flag with J/22 logo
J/30	Flag D
J/80	Flag J
J/105	Flag V

6.2 Boats are not required to fly class flags.

7 RACING AREA

7.1 The racing area will be in the Chesapeake Bay off the mouth of the Severn River as shown in SI Attachment 1.

7.2 The race committee starting vessel will be located in the vicinity of R"2".

7.3 Approximately 30 minutes prior to the first scheduled warning signal, the race committee will announce location of the anchored race committee signal vessel.

8 THE COURSES

8.1 The courses are shown in SI Attachment 2.

8.2 No later than the warning signal, the race committee signal vessel will display the course to be sailed, the approximate distance between the leeward and windward marks, and the approximate compass bearing of the first leg of the course.

8.3 If the race committee signal vessel displays flag C before the warning signal, accompanied by a series of repetitive sounds, the first mark of the course is to be a change mark.

9 MARKS

9.1 Starting marks, finishing marks, and mark 1a will be lime green cylinders. All other marks of the course will be orange cylinders. New marks used in accordance with SI 12 will be orange cylinders with a dark colored band.

9.2 A race committee starting or finishing vessel may set a stand-off buoy. When present, this stand-off buoy, the line attaching it to the race committee vessel, and the race committee vessel are all part of the starting or finishing mark.

10 THE START

10.1 Approximately 15 minutes before the warning signal, the race committee will announce the starting order for the first race of the day.

10.2 The starting line will be between the staff or halyard with an orange flag displayed on the race committee signal vessel and the course side of the starting mark.

- 10.3 [DP] Boats whose warning signal has not been made shall avoid the starting area during the starting sequence for other races.
- 10.4 A boat that does not start within 10 minutes after her starting signal will be scored Did Not Start without a hearing. This changes RRS A4 and A5.
- 11 RECALLS**
The race committee will announce on VHF radio boats identified as OCS, UFD, or BFD. Failure to hear or receive such broadcasts, the timeliness of broadcast or the order in which boats are announced, will not be grounds for redress. This changes RRS 62.1(a).
- 12 CHANGE OF THE NEXT LEG OF THE COURSE**
- 12.1 To change the next leg of the course, the race committee will lay a new mark (or move the finishing line) and remove the original mark as soon as practicable. When in a subsequent change, a new mark is replaced, it will be replaced by an original mark.
- 12.2 After a start, if flag C is flown over flag Q, then the course change applies only to boats beginning their final leg to the finish. This changes RRS 33 (Changing the Position of the Next Mark) and RRS Race Signals.
- 13 THE FINISH**
The finishing line will be between a staff or halyard displaying a blue flag on the race committee finishing vessel and the course side of the finishing mark.
- 14 PENALTY SYSTEM**
- 14.1 Penalties while racing: RRS 44.1, One-Turn and Two-Turns Penalties will apply.
- 14.2 Penalties after racing: RRS/US Appendix V2, Penalty Taken After the Race, will apply.
- 15 TIME LIMITS**
- 15.1 If no boat has passed the first mark within 45 minutes after the starting signal, the race will be abandoned.
- 15.2 In each class, the time limit is 90 minutes.
- 15.3 Boats failing to finish within 20 minutes after the first boat in her class sails the course and finishes, and not subsequently retiring, penalized or given redress, will be scored Time Limit Expired (TLE) without a hearing. This changes RRS 35, A4 and A5.
- 16 PROTESTS, REQUESTS FOR REDRESS, SCORING INQUIRIES**
- 16.1 Protest forms are available at annapolisyc.org/racing/protest and at the race office, located in the Sailing Office at the AYC Sailing Center. Protests, requests for redress or reopening shall be delivered there within the protest time limit. These may alternatively be delivered by email to raceoffice@annapolisyc.org.
- 16.2 Scoring inquiry forms are available at annapolisyc.org/racing/protest and at the race office. They can be delivered there or by email to raceoffice@annapolisyc.org. When the race committee receives a scoring inquiry form, it will review its records and respond as soon as practicable.
- 16.3 The protest time limit is 60 minutes after the race committee signal vessels docks. The race committee will post the protest time limit.
- 16.4 The race committee will post a list of race committee scoring actions no later than the protest time limit.
- 16.5 Notices of protests by the race committee or protest committee will be posted to inform boats under RRS 61.1(b).
- 16.6 As soon as practicable after the protest time limit, the protest committee will post a notice to inform competitors of the schedule and location of hearings in which they are parties or named as witnesses. Hearings will be held at the Sailing Office at the AYC Sailing Center.
- 17 SCORING**
- 17.1 RRS Appendix A4, Low Point System, will apply.
- 17.2 One race is required to be completed to constitute a series.
- 17.3 A boat's series score will be the total of her race scores.
- 17.4 Boats to be scored TLE will be scored points equal to the number of boats finishing within the finishing window plus two points by the race committee without a hearing but no worse than the number of entries. This changes RRS A4.2 and A5.
- 18 SAFETY REGULATIONS**
- 18.1 [DP] A boat that retires from a race, or leaves the racing area between races, shall notify the race committee at the first reasonable opportunity.
- 18.2 [NP] [DP] A boat shall not exercise right of way, cross in proximity to, or interfere with reasonable transit of the race area by commercial ships, tugs, or barges. Boats must take evasive action well in advance of a potentially dangerous situation. The US Coast Guard, ship captains, and bay pilots have been encouraged to report any incident they observe.
- 18.3 A boat without way may use any means of propulsion to avoid commercial traffic that is under way provided: (a) the boat does not gain an advantage; (b) use of the propulsion is the boat's only means of avoiding the commercial traffic; and (c) the boat submits a report to the race office (in writing or by e-mail to raceoffice@annapolisyc.org) by the protest filing deadline describing the incident and the boat's actions.

18.4 The race committee or protest committee may protest a boat for SI 18.2 based on information received from any source. The protest time limit does not apply. This changes RRS 60.2, 60.3, and 61.3.

19 PRIZES

19.1 First, second, and third place awards will be presented for the J22 and J105 classes (those that had 5 entries per NoR 2.5).

19.2 Awards will be presented after racing at the AYC Sailing Center.

20 DISCLAIMER OF LIABILITY

Competitors participate in the regatta entirely at their own risk. See RRS 4, Decision to Race. The organizing authority will not accept any liability for material damage or personal injury or death sustained in conjunction with or prior to, during, or after the regatta.

SI ATTACHMENT 1 - RACE AREA

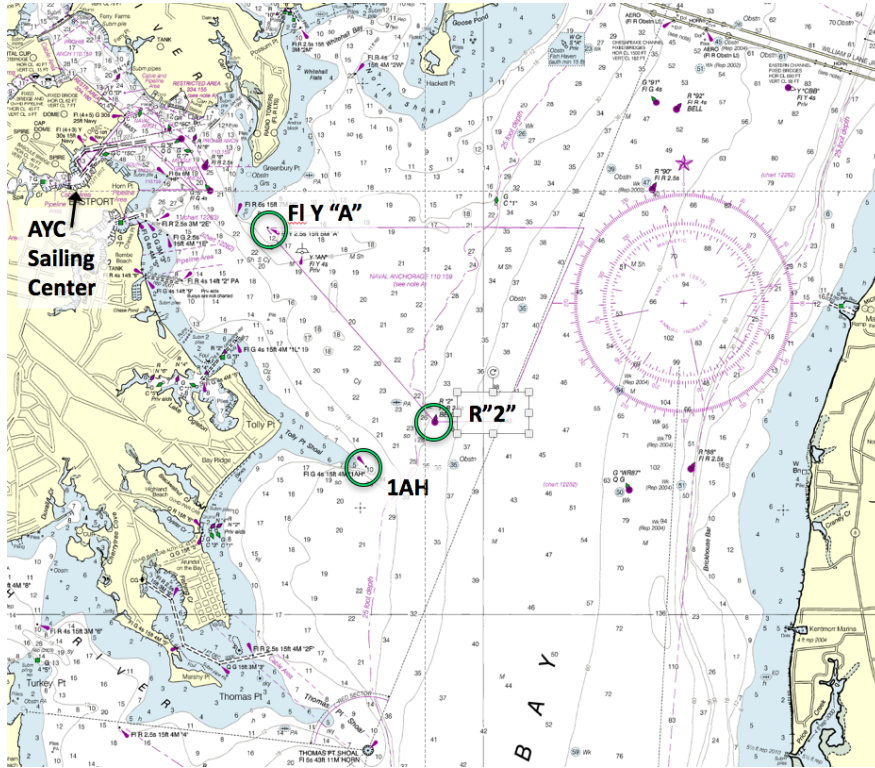

SI ATTACHMENT 2 - COURSES

In the below table, the course designation is followed by the mark rounding order for that course. All marks except 2S are to be rounded to port. If the race committee displays "NO GATE" near the course designation, then mark 2S will not be set. If there is a conflict between the color or shape of a mark below and SI 9 (Marks), SI 9 will govern.

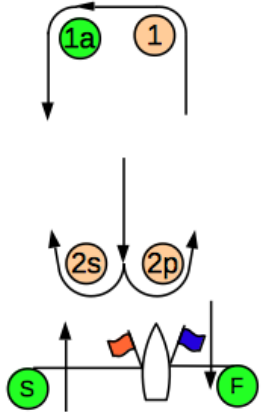
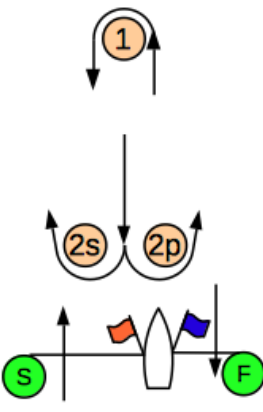
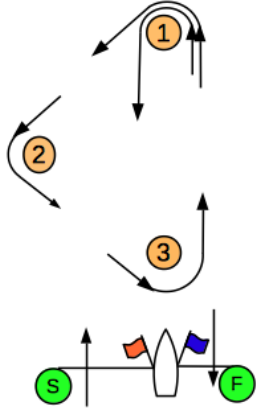
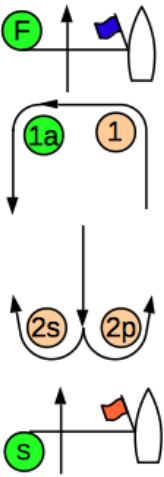
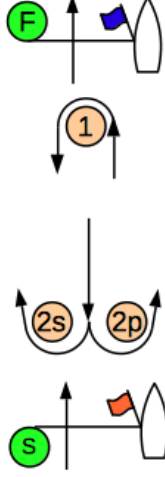
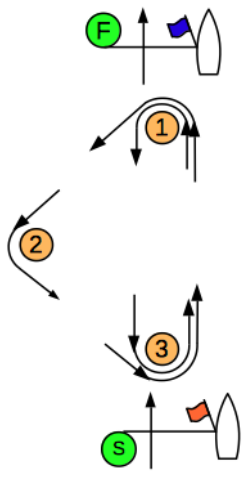
<div style="font-size: 2em; font-weight: bold; margin-bottom: 10px;">LA</div>  <p style="margin-top: 20px;">LA2: Start-1-1a-2s/2p-1-1a-Finish LA3: Start-1-1a-2s/2p-1-1a-2s/2p-1-1a-Finish</p>	<div style="font-size: 2em; font-weight: bold; margin-bottom: 10px;">L</div>  <p style="margin-top: 20px;">L2: Start-1-2s/2p-1-Finish L3: Start-1-2s/2p-1-2s/2p-1-Finish</p>	<div style="font-size: 2em; font-weight: bold; margin-bottom: 10px;">TL</div>  <p style="margin-top: 20px;">TL2: Start-1-2-3-1-Finish TL3: Start-1-2-3-1-3-1-Finish</p>
<div style="font-size: 2em; font-weight: bold; margin-bottom: 10px;">WA</div>  <p style="margin-top: 20px;">WA2: Start-1-1a-2s/2p-Finish WA3: Start-1-1a-2s/2p-1-1a-2s/2p-Finish WA4: Start-1-1a-2s/2p-1-1a-2s/2p-1-1a-2s/2p-Finish</p>	<div style="font-size: 2em; font-weight: bold; margin-bottom: 10px;">W</div>  <p style="margin-top: 20px;">W2: Start-1-2s/2p-Finish W3: Start-1-2s/2p-1-2s/2p-Finish W4: Start-1-2s/2p-1-2s/2p-1-2s/2p-Finish</p>	<div style="font-size: 2em; font-weight: bold; margin-bottom: 10px;">TW</div>  <p style="margin-top: 20px;">TW2: Start-1-2-3-Finish TW3: Start-1-2-3-1-3-Finish</p>



81st AYC Annual Regatta 2017

Organizing Authority: Annapolis Yacht Club
Annapolis, Maryland, USA

Event Website: <http://www.annapolisyc.com/racing/regattas>

SAILING INSTRUCTIONS (with Amendment 1) FIXED MARKS COURSE

The notation '[DP]' in a rule in the sailing instructions (SIs) or notice of race (NoR) means that the penalty for a breach of that rule may, at the discretion of the protest committee, be less than disqualification. The notation '[NP]' in a rule of the SIs or NoR means that a boat may not protest another boat for breaking that rule. This changes RRS 60.1(a).

1 RULES

1.1 The regatta will be governed by the rules as defined in The Racing Rules of Sailing (RRS).

2 COMMUNICATIONS WITH COMPETITORS

2.1 Notices to competitors will be posted on the official notice board at:
https://yachtscoring.com/notice_board_summary.cfm?elD=3030

2.2 On the water, the race committee intends to monitor and communicate with competitors via VHF radio on channel 72.

3 CHANGES TO SAILING INSTRUCTIONS

3.1 Any change to the SIs will be posted no later than 2 hours before the first scheduled warning signal on the day it will take effect, except that any change to the schedule of races will be posted by 2000 on the day before it will take effect.

4 SIGNALS MADE ASHORE

4.1 Signals flown ashore will be flown from the flagpole at the AYC Junior Sailing Center.
4.2 When flag AP is displayed ashore, '1 minute' is replaced with 'not less than 60 minutes' in the race signal AP.

5 SCHEDULE OF RACES





5.1 The starting schedule will be:

Time	
1100	Warning: Cruising Spinnaker, Non-Spin
1105	Start: Cruising Spinnaker, Non-Spin
1110	Warning: PHRF A1, A2, B
1115	Start: PHRF A1, A2, B

5.2 One race is scheduled for each class
5.3 No warning signal will be made after 1600.
5.4 All competitors are invited to a post-race party and awards presentation at the AYC Sailing Center at 1800 with complimentary beer and hors d'oeuvres.

6 CLASS FLAGS

6.1 The class flags are:

Class	Class flag
Cruising Non-spinnaker	Flag 5 
Cruising Spinnaker	Flag 4 
PHRF B	Flag 6 
PHRF A2	Flag 2 
PHRF A1	Flag 9 

6.2 A boat shall clearly display two class flags - one at the bow (from the bow pulpit if available) and one at the stern (approximately 5 feet up on the backstay if the boat has a backstay).

7 RACING AREA

7.1 The racing area will be in the Chesapeake Bay off the mouth of the Severn River.

8 THE COURSES

8.1 The courses will be as shown in Attachment A.
8.2 No later than the warning signal the race committee signal boat will display the course to be sailed and announce the course on VHF Channel 72.

9 MARKS

9.1 Starting and finishing marks will be lime green cylinders. All other marks of the course will be government marks.
9.2 A race committee starting or finishing vessel may set a stand-off buoy. When present, this stand-off buoy, the line attaching it to the race committee vessel, and the race committee vessel are all part of the starting or finishing mark.

10 THE START

10.1 The starting line will be between the staff or halyard with an orange flag displayed on the race committee signal vessel and the course side of the starting mark.

- 10.2 [DP] Boats whose warning signal has not been made shall avoid the starting area during the starting sequence for other races.
- 10.3 A boat that does not start within 10 minutes after her starting signal will be scored Did Not Start without a hearing. This changes RRS A4 and A5.
- 11 RECALLS**
The race committee will announce on VHF radio boats identified as OCS, UFD, or BFD. Failure to hear or receive such broadcasts, the timeliness of broadcast or the order in which boats are announced, will not be grounds for redress. This changes RRS 62.1(a).
- 12 CHANGE OF THE NEXT LEG OF THE COURSE**
12.1 After the starting signal, the course will not be changed. The course may be shortened in accordance with RRS 32 at any rounding mark.
- 13 THE FINISH**
The finishing line will be between a staff or halyard displaying a **BLUE** flag on the race committee finishing vessel and the course side of R"2". Note that the finishing vessel might not be the starting signal vessel.
- 14 PENALTY SYSTEM**
14.1 Penalties while racing: RRS 44.1, One-Turn and Two-Turns Penalties will apply.
14.2 Penalties after racing: RRS/US Appendix V2, Penalty Taken After the Race, will apply.
- 15 TIME LIMITS**
15.1 The time limit for all boats is 1630. Boats failing to finish before the time limit, and not subsequently retiring, penalized or given redress, will be scored Time Limit Expired (TLE) without a hearing. This changes RRS 35, A4 and A5.
- 16 PROTESTS, REQUESTS FOR REDRESS, SCORING INQUIRIES**
16.1 Protest forms are available at annapolisyc.org/racing/protest and at the race office, located in the Sailing Office at the AYC Sailing Center. Protests, requests for redress or reopening shall be delivered there within the protest time limit. These may alternatively be delivered by email to raceoffice@annapolisyc.org.
16.2 Scoring inquiry forms are available at annapolisyc.org/racing/protest and at the race office. They can be delivered there or by email to raceoffice@annapolisyc.org. When the race committee receives a scoring inquiry form, it will review its records and respond as soon as practicable.
16.3 The protest time limit 2 hours after the last boat has finished the last race of the day or the race committee signals no more racing today,
- whichever is later. The race committee will post the protest time limit.
- 16.4 The race committee will post a list of race committee scoring actions no later than the protest time limit.
- 16.5 Notices of protests by the race committee or protest committee will be posted to inform boats under RRS 61.1(b).
- 16.6 As soon as practicable after the protest time limit, the protest committee will post a notice to inform competitors of the schedule and location of hearings in which they are parties or named as witnesses. Hearings will be held at the Sailing Office at the AYC Sailing Center.
- 17 SCORING**
17.1 RRS Appendix A4, Low Point System, will apply.
17.2 One race is required to be completed to constitute a regatta.
17.3 Corrected times for classes using PHRF will be calculated using PHRF Time-on-Time scoring with a boat's Circular-Random rating. A boat's corrected time will be her elapsed time multiplied by $(650 / (550 + \text{Phrf Rating}))$.
17.4 Corrected times for classes using ORC will be calculated using ORC Time-on-Time Coastal/Long Distance rating.
17.5 Boats to be scored TLE will be scored points equal to the number of boats finishing within the finishing window plus two points by the race committee without a hearing but no worse than the number of entries. This changes RRS A4.2 and A5.
- 18 SAFETY REGULATIONS**
18.1 [DP] A boat that retires from a race, or leaves the racing area between races, shall notify the race committee at the first reasonable opportunity.
18.2 [NP] [DP] A boat shall not exercise right of way, cross in proximity to, or interfere with reasonable transit of the race area by commercial ships, tugs, or barges. Boats must take evasive action well in advance of a potentially dangerous situation. The US Coast Guard, ship captains, and bay pilots have been encouraged to report any incident they observe.
18.3 A boat without way may use any means of propulsion to avoid commercial traffic that is under way provided: (a) the boat does not gain an advantage; (b) use of the propulsion is the boat's only means of avoiding the commercial traffic; and (c) the boat submits a report to the race office (in writing or by e-mail to raceoffice@annapolisyc.org) by the protest filing deadline describing the incident and the boat's actions.
18.4 The race committee or protest committee may protest a boat for SI 18.2 based on information received from any source. The protest time limit

does not apply. This changes RRS 60.2, 60.3, and 61.3.

19 PRIZES

- 19.1 First, second, and third place awards will be presented for the A2 class (having had 5 entries per NoR 2.5).
- 19.2 Additional prizes may be awarded at the discretion of the organizing authority.

- 19.3 Awards will be presented after racing at the AYC Sailing Center.

20 DISCLAIMER OF LIABILITY

Competitors participate in the regatta entirely at their own risk. See RRS 4, Decision to Race. The organizing authority will not accept any liability for material damage or personal injury or death sustained in conjunction with or prior to, during, or after the regatta.

SI ATTACHMENT A - COURSES

Course	Rounding Side	Rounding Order	Distance
A	Port	Start near R"2", GR C "SR", R "86", R "88", Finish at R"2"	11.4
B	Port	Start near R"2", G "1", R "86", R "88", Finish at R"2"	13.6
C	Port	Start near R"2", R "84A", R "86", R "88", Finish at R"2"	19.5
AR	Starboard	Start near R"2", R"88", R"86", GR C "SR", Finish at R"2"	11.4
BR	Starboard	Start near R"2", R"88", R"86", G "1", Finish at R"2"	13.6
CR	Starboard	Start near R"2", R"88", R"86", R "84A", Finish at R"2"	19.5

For ALL courses, the following navigational aids rank as passing marks and shall be passed on the channel side at all times: Tolly Point Dolphin ("1AH"); Thomas Point Shoal Light; Bloody Point Bar Light.

